



TRULINE<sup>™</sup>  
VINYL SHEET PILING

Profextru  
PRODUCTIE BV

## APE Hybrid Technology

**“...enhancing the performance of traditional materials, with the benefits of synthetics..”**

*“...the most significant innovation in synthetic piling for over a decade.”*



*“..whilst plastic piling continues to imitate traditional steel pile designs, it will always be the poorer relative...”*

New advanced designs  
aesthetic and structural

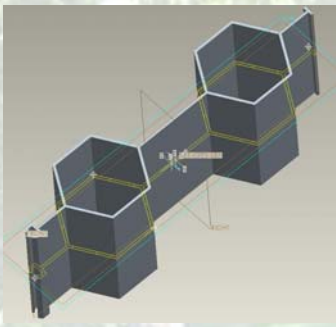

### The MultiLock

APE biggest selling plastic pile, uniquely popular within DIY as within major civil engineering projects.

The secret is the innovative symmetrical tubular design, providing exceptionally high rigidity and installation durability.

Use on its own for cut-off wall applications and micro dams, or used as a king panel with timber posts or steel tubes. A full range of bending moments within one product design. If you can drive steel or timber, you can drive MultiLock

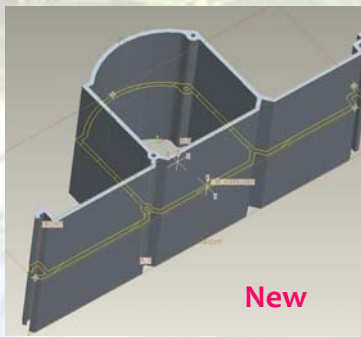

### New ProLock

ProLock is the heavier duty version of the MultiLock, also working with timber or steel, except that ProLock accepts up to 160mm diameter and so will withstand greater loading. The design has just been improved from the original open front design to this new stronger, more rigid design.

This product is ideally suited to bank stabilisation, retaining walls and erosion control. Depending on loadings this product has been used to support a 3m retaining height.

The internal strengthening makes this product ideal when anchors and tiebacks are not possible, in most cases simply substitute timber for steel tubes. This product is fast being the Marina pile!

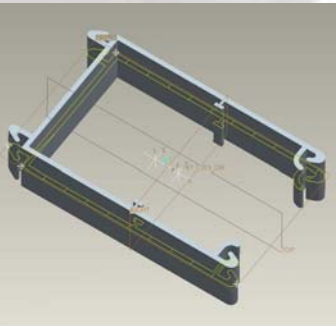

### Truline Series 800

The original hybrid pour-in-place erosion control solution. Made from 94.6% post industrial materials. The unique modular system, produces a flat frontage structure, ideally suited to bank stabilisation, erosion control and retaining walls.

The printed specifications are based upon a full or partial in fill of gravel / densified soil. Recent test have evaluated for the first time Series 800 fully filled with 4000psi concrete and 1% by area reinforcing steel on the tension side of the column. The concrete had cured for 40 days.

The results showed that the flexural stiffness for the beam (EI) was 934,000,000 lbin<sup>2</sup>. This compares to 25,000,000 for a gravel filled sheet.

**Essentially the 1% reinforced concrete filled sheet is 37 times stronger. Still think that plastic piling cannot be structural?**

Truline has also been considered in this instance as a bearing pile, in addition to a retaining wall. No test have yet been conducted to confirm its suitability, for instance in the construction of basements.



# APE Plastic Piling

Tel 01543 277680  
 Fax 01543 270090  
 Email [info@miniape.com](mailto:info@miniape.com)  
[www.miniape.com](http://www.miniape.com)